

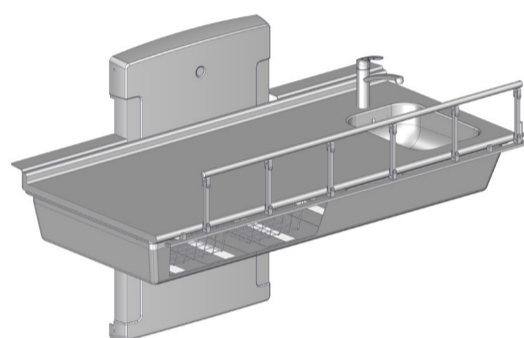

75 kg, 165 lbs

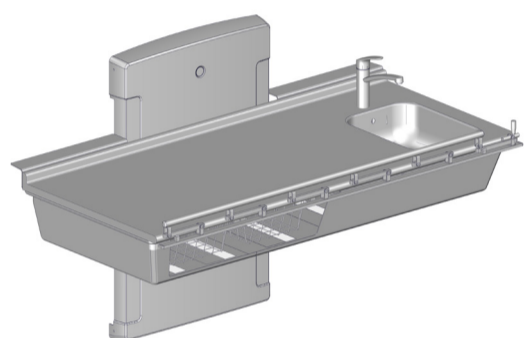

①

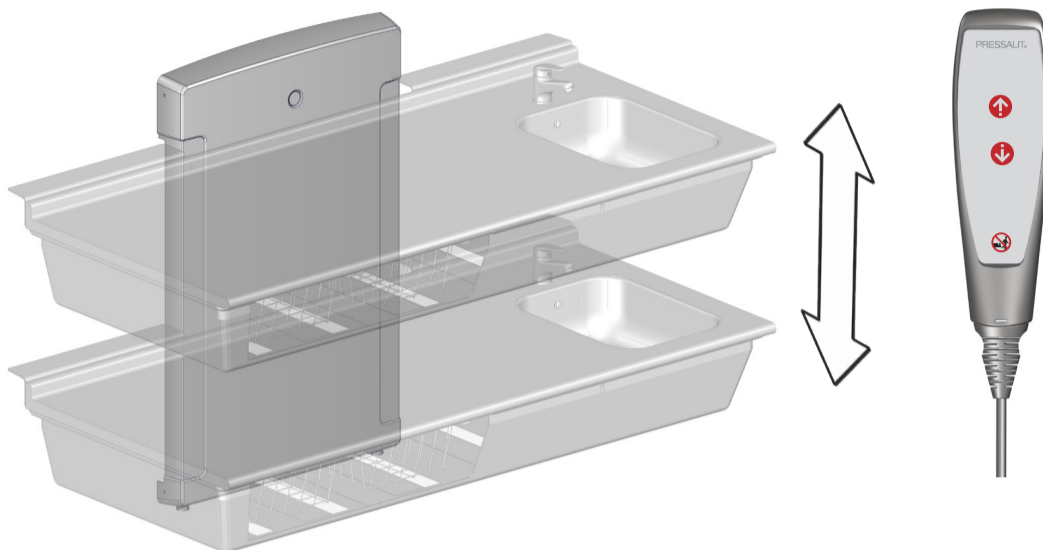
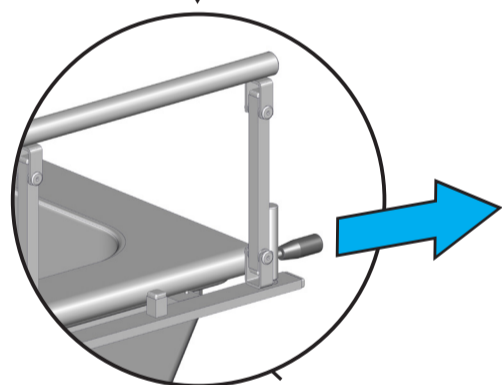

②

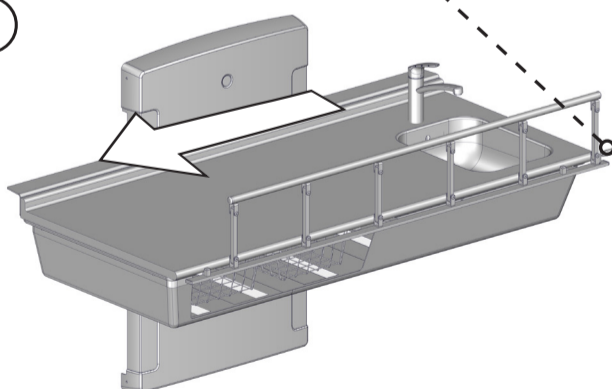

③

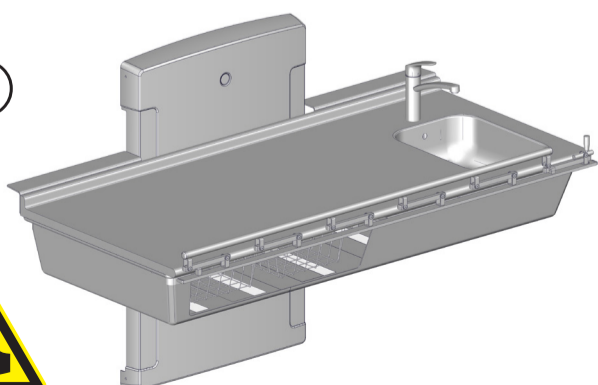

①

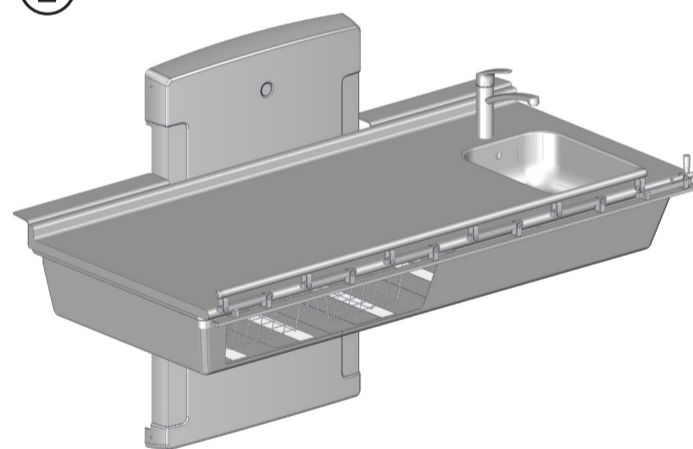

②

